

NL5000

Wireless Modem



NL5000 User Manual

Data Only Rev 1.2

rfneulink
DIVISION OF RF INDUSTRIES

WWW.RFNEULINK.COM

TABLE OF CONTENTS

1.0 Introduction	3
1.1 Genreal	4
1.2 Model Identification	3
1.3 FCC Regulations.....	4
2.0 Specifications	5
2.1 Genreal	5
2.2 Transmitter	6
2.3 Receiver.....	6
3.0 NL5000 I/O Connectors and Indicators.....	7
3.1 15-Pin I/O Connector	7
3.2 Indicators.....	8
3.3 NL5000 - DB 15 to DB 9 Interface Cable	9
4.0 Accessories	9
5.0 Operation	10
5.1 Channel Selection.....	10
5.2 Power Supply Voltage	10
5.3 Duty Cycle/Key-Down Limitations	11
5.4 Operating Modes	12
5.5 Antenna Placement	12
5.6 Analog/Voice Interface.....	13
5.7 Data Stream Packet Detection Modes	13

6.0 Configuration Software	14
6.1 PC Configuration Software Kit	14
6.2 Loading The Configuration Software	15
6.3 Computer Software Copyrights	15
6.4 Using The Configuration Software.....	15
6.5 Configuration Software Buttons.....	16
6.6 Configuration Software Drop-Down Menus.....	17
 APPENDIX	 22

1.0 Introduction

1.1 GENERAL

The NL5000 modem is a wireless modem designed to operate on the licensed land mobile frequency bands at VHF, UHF, and 220 MHz. It supports over-the-air data rates of up to 4800 bps in a 6.25 kHz channel, 9600 bps in a 12.5 kHz channel, and 19.2 kbps in a 25 kHz channel. Besides offering data communications, the NL5000 modem includes voice transceiver audio input and outputs. The complete modem transceiver is housed in the standard NL5000 case, resulting in a light, compact package.

1.2 MODEL IDENTIFICATION

The NL5000 modem has a part number in the form of "NL5000-VHF/LN"

Where:

The NL5000 is followed by the next major frequency band designator:

VHF
220 MHz
UHF

"L" is the Low portion of the sub-band designator:

L=136-162 for VHF and 400-420 for UHF

"H" is the High portion of the sub-band designator:

H=148-174 for VHF, and 450-470 for UHF

"N" designates the channel bandwidth:

S=6.25 kHz
N=12.5 kHz
W=25 kHz

Example: A NL5000-UHF/HN would be a UHF module for operation between 450 and 470 MHz, narrow (12.5 kHz channel spacing) IF bandwidth.

1.3 FCC REGULATIONS

1.3.1 Licensing

The FCC requires that the radio owner obtain a station license for his radio before using the equipment to transmit, but does not require an operating license or permit. The station licensee is responsible for proper operation and maintenance of his radio equipment, and for ensuring that transmitter power, frequency and deviation are within the limits specified by the station license. This includes checking the transmitter frequency and deviation periodically using appropriate methods.

1.3.2 Equipment Authorization (Certification)

The unit is certified for transmission of either voice or data signals when aligned according to the alignment procedure for the proper bandwidth and when operated as a complete unit in the metal case. Operation of the RF board as a stand-alone unit or in combination with any other equipment, in any mode outside the alignment procedure, or with the clipper filter electronically disabled will require the filing of a new certification application with the FCC by the user.

1.3.3 Standards

The FCC, with its action in General Docket 79-144, March 13, 1985, adopted a safety standard for human exposure to radio frequency electromagnetic energy emitted by FCC regulated equipment.

The NL5000 product family has been evaluated for compliance with the maximum exposure limits for RF energy at the maximum power rating of the unit and with the only antenna sold for use with this product by RF NEULINK. To ensure compliance with the General Population/Uncontrolled maximum exposure limits, please observe the following:

When the RF Neulink RAM-1545 remote magnetic mount antenna is used, mount the antenna in a location that will ensure that all persons will be located 8.0 inches away from the antenna of all models

Antennas other than the RF Neulink RAM-1545 must be tested with the NL5000 for RF exposure compliance in the environment in which it is to be used per the FCC's OET Bulletin 65, Edition 97-01 or Industry Canada RSS-102.

2.0 SPECIFICATIONS

2.1 GENERAL

FCC Rule Parts	90
IC Rule Parts	RSS-119
Data rate (bps)	
6.25 kHz channel	4800 bps
12.5 kHz channel	9600 bps
25 kHz channel	19,200 bps
Modulation	
Voice	Direct FM
Data	4FSK
Over-the-Air Protocol	RF Neulink Proprietary
Number of Channels	2 (8 via software)
Operating Bandwidth	
VHF	26 MHz
UHF	20 MHz
220 MHz	28 MHz
Synthesizer Step Size	
VHF	2.5 kHz
UHF	5.0/6.25 kHz
220 MHz	2.5/3.125 kHz
Emissions Bandwidth	
Voice	
12.5 kHz channels	10.0 kHz
25 kHz channels	15.0 kHz
Data	
6.25 kHz channels	4.8 kHz
12.25 kHz channels	9.6 kHz
25 kHz channels	19.2 kHz
Frequency Stability	
-30°C to +50°C	+/- 1.0 ppm
-30°C to +60°C	+/- 1.5 ppm
-30°C to +75°C	+/- 2.5 ppm
Supply Voltage	
D-version	7.5+/-0.5 VDC
I, L-versions	11-16 VDC
RF Connector	BNC
Power/Data Connector	15-pin subminiature D-type
Dimensions (LxWxH)	3.6"x 2.3" x1.0"
Weight	6 oz
Indicators	Transmit LED, Receive LED

2.2 TRANSMITTER

RF Output Power	
VHF	1-6 watts
UHF	1-3 watts, 1-6 watts
220 MHz	1-6 watts
RF Load Impedance	50 ohms resistive, VSWR 1.5:1 or less
PTT attack time	15 ms max.
Spurious and Harmonics	-25 dBm max.
FM Hum and Noise	
6.25 kHz channel	35 dB min.
12.5 kHz channel	40 dB min.
25 kHz channel	45 dB min.
Current Drain	
1 watt	1.1 A max.
2 watts	1.6 A max.
6 watts	2.7 A max.

2.3 RECEIVER

Sensitivity	
Voice (12 dB SINAD)	0.25 uV max.
Data (10 ⁻⁵ BER)	0.30 uV max.
Adjacent Channel Selectivity	
6.25 kHz channel	50 dB min.
12.5 kHz channel	60 dB min.
25 kHz channel	70 dB min.
Spurious and Image Rejection	70 dB min.
IMD Rejection	67 dB min.
FM Hum and Noise	
6.25 kHz channel	35 dB min.
12.5 kHz channel	40 dB min.
25 kHz channel	45 dB min.
Conducted Emissions	-57 dBm max.
Squelch Attack Time	15 ms max.
Receive Current Drain	120 mA max.

3.0 NL5000 I/O CONNECTOR AND INDICATORS

3.1 15-PIN I/O CONNECTOR - DATA ONLY

Connector Pinout

Pin	Name	Description	Comments
1			Not used for Data
2			Not used for Data
3			Not used for Data
4	A/B	Input	Channel 1/2 or High/Low power
5	NC		Not Used
6	Supply	Input	DC Power + input connects here to power unit
7	NC	Output	Receiver Alignment-Do NOT CONNECT
8	RD	Output	RS-232 data output from modem
9	TD	Input	RS-232 data input to the modem
10	CTS	Output	RS-232 clear to send output from modem
11	DSR	Output	RS-232 data set ready output from modem
12	TEST	Input	Used for PTT (Not used for Data)
13	CD	Output	Carrier Detect
14	RTS	Input	RS-232 request to send input to modem
15	GND		System ground - Power Supply I/P connection

Pinout Description – DB 15

Pin 4 A/B

Depending on how it is programmed via the Configuration Software, this pin can either be a channel A/channel B selection pin or a high/low transmit power selection pin. This pin has an internal pullup resistor to +5 volts and assumes a high (channel A or high power) state when left unconnected.

Pin 5 Not Used

Pin 6 SUPPLY

This is the positive power supply input for the modem.

Pin 8 RD (Receive Data)

RS-232 data to be received from the modem is available at this pin. The data are at normal RS-232 levels and are **transmitted from the modem to be received by the host computer** or other device connected to the modem.

Pin 9 TD (Transmit Data)

RS-232 data to be transmitted to the modem should be presented to this pin. The data should be at normal RS-232 levels and are **transmitted from the host computer or other devices to the modem.**

Pin 10 CTS (Clear to Send)

This RS-232 output pin is asserted by the modem as a response to an assertion of the RTS pin when it is ready and able to receive data from the host computer or device.

Pin 11 DSR (Data Set Ready)

This RS-232 output pin is asserted by the modem when it is powered-up. It indicates that the modem is actually connected, although not necessarily ready to receive data. The polarity (active low/active high) is programmable via the Configuration Software.

Pin 13 CD (Carrier Detect)

This pin is asserted by the modem when the receiver has detected a carrier. The RF level set point is set via the Configuration Software. Note that the modem demodulation circuitry does not actually use this signal to determine that a valid data packet has been received. The polarity (active low/active high) is programmable via the Configuration Software

Pin 14 RTS (Request to Send)

This RS-232 input pin is asserted by the host computer or device to indicate that it has data to be transmitted by the modem. If the modem is able to accept the data, the CTS pin will be asserted in response.

Pin 15 GND (Ground)

The system ground common point and negative connection for the power supply input.

3.2 INDICATORS

The NL5000 Modem has two indicators on the side of the unit, one green RX LED and one red TX LED. They function as follows:

GREEN RX LED-This indicator is illuminated when the modem has detected a valid preamble for a data packet. This indicator reflects the behavior of the modem's packet detection system, not the fact that a signal may actually be

present. To determine the presence of a carrier, one can monitor the state of the Carrier Detect output .

RED TX LED-This indicator is illuminated when the modem is transmitting.

3.3 NL5000 - DB 15 to DB 9 Interface Cable

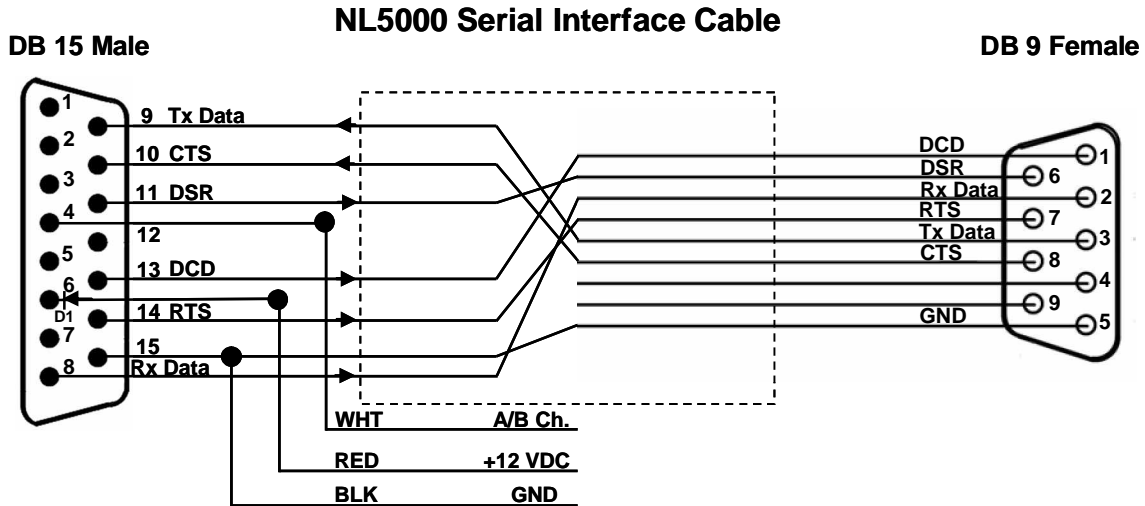

The above interface cable facilitates the connection of standard RS-232 signals to a typical 9 pin “D” type female connector. This cable additionally accommodates the connection of the +12 VDC, Ground and the A/B power or channel selector to the 15 pin “D” type female connector on the NL5000 front panel. As shown, D1 is placed in series between pin 6 and the + 12 VDC supply voltage and provides reverse polarity protection.

4.0 ACCESSORIES

Note: Configuration Software kits are for use by authorized service/maintenance personnel only.

The Configuration Software Kit for NL5000 (via compatible computer) is model NL5000P-PCKT. It includes:

1. Configuration Software disk, CD (qty 1).
2. A Configuration Software/Power cable with a DB-15 Male connector on one end for connection to the NL5000 modem and a cable to a DB-9 Female connector for connection to the host computer and two wires, one red (positive) and one black (negative) for connections to a power supply.

Factory Configuration of channels and features is also optional. Contact the factory for details.

5.0 OPERATION

5.1 CHANNEL SELECTION

Via the 15-pin connector, the NL5000 supports one channel if the A/B pin (pin 4) is programmed for high/low power and two channels if the A/B pin is programmed as a channel select input. Channel A is set when the A/B pin is activated and the A/B pin is in the logic high state i.e. above 3.5 volts DC or left unconnected (There is an internal pull-up resistor on the A/B pin). Channel B is set when the A/B pin is activated and the A/B pin is in the logic low state i.e. below 0.5 volts DC. If the A/B pin is programmed for high/low power, channel A is always selected.

Internally, the NL5000 can store eight (8) channels. The first one or two are selected via the 15-pin A/B pin, but the remaining channels can be selected within the Configuration Software or via a special channel select command through the RS-232 connection.

A change in the channel selection in receive will cause the receiver to operate on the new channel. In transmit, however, the channel selection is only checked only at the beginning of a transmission. Changes in channel during transmit will not change the transmit operating channel of the unit until the unit is cycled from transmit to receive and back to transmit.

5.2 POWER SUPPLY VOLTAGE

Pin 6 is the positive supply input to the unit. The type of module determines the actual voltage that should be applied to this pin. One should be absolutely sure of the proper voltage and current requirements before applying power.

Three voltages are used within the unit; +5 volts for the processor and logic circuits along with most of the receiver, +7.5 volts for the transmitter driver stages, and the supply voltage for the RF power module which depends upon which module is used.

The VHF unit and the 3 and 6-watt UHF units use 7.5 volt RF power modules. Two supply voltage options are available for these units depending upon whether the modem board has a regulator installed. If a regulator is not installed, the voltage should be 7.5 volts +/-10 %. This voltage should be "clean" and preferably regulated since the RF power module is powered directly from this source. Variations in voltage will cause variations in transmitted output power. Conversely, if the control/loader board has a regulator installed, the supply voltage can be at any voltage between 10 and about 15 volts. Although the use of the regulator allows flexibility in terms of supply voltage, because of the

amount of heat generated by the regulator, significant duty cycle/key down limitations may apply (see below).

The RF power module in the 10 watt UHF unit requires at least 12 volts to achieve 10 watts, although voltages as high as 15 may be used. Since the module is powered directly from this voltage, the supply should be “clean” and, preferably, regulated. The output power will vary with supply voltage. The 7.5 volts required for the transmitter driver stages is developed by a regulator, but since the current requirements are limited, the regulator is not a factor in determining the duty cycle/key down limits.

5.3 DUTY CYCLE/KEY-DOWN LIMITATIONS

The major heat generating components within the module such as the RF power amplifier and voltage regulator (if used) have maximum temperature limits that should not be exceeded. In addition, the temperature within the module itself must be kept below the maximum temperature of the reference oscillator. As a result, depending upon power, supply voltage, and temperature, limits upon the average transmit duty cycle and the maximum continuous transmitter on time exist. These limits are summarized below for operation in still air:

	Temperature (°C)	Duty Cycle (%)	Key-DownTime (s)
With internal regulator	60	5	5
3 watt RF output	25	50	20
	60	5	5
6 watt RF output	25	30	15
	60	5	5

Blowing air across the unit and/or adding heat sinks can significantly improve the duty cycle/key-down times, especially in units without the internal regulator.

5.4 OPERATING MODES

5.4.1 Digital/Data Mode

The primary mode of operation of the NL5000 modem is that of transmitting digital data. Data received through the RS-232 pins on the I/O connector are combined with error detecting and correcting bits along with bit synchronization and framing pattern bits and converted into a 4-level pattern to be transmitted. The data stream to be transmitted is also broken into blocks and then into packets or frames (a collection of blocks) for easier error detection and correcting. The speed (baud rate) of the stream is dependent upon the channel bandwidth and varies from 4800 bps (2400 baud) in a 6.25 kHz channel to 19.2 kbps (9600 baud) in a 25 kHz channel. The actual data throughput is about half that of the over-the-air speed due to the extra bits added as discussed above. At the receiving end, the 4-level data stream is decoded and the information is passed to the host.

The length of the blocks is fixed, but the overall packet length can vary and depends upon the timing of the reception of the data through the RS-232 pins. The packets are formed as the length of the data stream reaches a certain limit, determined by the modem itself or when a time gap in the reception of the data occurs.

5.4.2 Voice/Analog Mode

In many situations it is desirable to be able to transmit voice or analog information. This can be useful in determining whether an RF link has been established and in troubleshooting situations. The NL5000 modem supports voice and analog input signals in the 12.5 kHz and the 25 kHz versions; the 6.25 kHz version cannot support voice due to its narrow bandwidth. The audio path gains on both the transmitter and receiver are programmable via the Configuration Software. The receiver has two audio outputs, one for line level operation and one which is able to drive a speaker.

5.5 ANTENNA PLACEMENT

The NL5000 module is enclosed in a metal housing for RF shielding. However, RF emitting sources located very close (less than 12 inches) to the unit can at times affect its operation. It is not recommended that an antenna be connected directly to the module's BNC connector unless the RF output power is set for less than 1 watt or the module is placed within another RF tight enclosure.

In addition, to ensure that persons are not exposed to RF levels above safe limits, observe the antenna to personnel distance limits in section 1.3.3.

5.6 ANALOG/VOICE INTERFACE

5.6.1 Transmitter

The analog/voice input for the modem is on pin 1 (AUDIO IN) of the 15-pin I/O connector. Signals at this input are modulation limited and filtered before being presented to the modulator. Via the Configuration Software, the gain of this signal path can be adjusted and pre-emphasis or a flat audio response can also be selected. Transmitting a signal from this input normally requires that the pin 12 (TEST) of the I/O connector be taken to the active state. The active state can be set via the Configuration Software and is normally set for active low logic level. Note that the TEST pin can be set via the Configuration Software to send other types of signals such as digital test patterns and must be set via the Configuration Software to activate the analog/voice channel and transmit the analog/voice signal when asserted.

5.6.2 Receiver

The receiver has two audio outputs, a line level output and an output which can drive a speaker load. There are a number of parameters which can be set via the Configuration Software for these two outputs. The line level output on pin 2 (AUDIO OUT) of the 15-pin I/O connector can be selected to have either a flat or de-emphasized audio response and its level can be adjusted. Pin 3 (SPEAKER) of the 15-pin I/O connector is the output of the audio PA and is capable of driving 8-ohm speaker loads. This output is always de-emphasized and its level is set via the Configuration Software with the same adjustment as the AUDIO OUT signal. Note that the AUDIO OUT and SPEAKER levels cannot be set independently since they share the same adjustment.

In order for audio to be present at either of these outputs, the received signal RF level must be above the carrier detect level set via the Configuration Software. Both the carrier detect on and carrier detect off levels can be set and are the same as the levels used by the data modem when the modem is set to use carrier detect for the detection of a packet (see below).

5.7 DATA STREAM PACKET DETECTION MODES

In order for the receive modem to properly synchronize to a transmitted packet of data, the packet data blocks are preceded by a bit synchronizing block and a frame synchronizing block. The receive modem looks for the bit synchronizing pattern to determine that a packet of data is forthcoming. The modem can be programmed to do this continuously on the raw discriminator output or only when a signal has been detected on the basis of the carrier detect circuitry.

There is a tradeoff in choosing between these two modes. If the radio's carrier detect circuitry is not used, the modem must continuously sample the noise and other signals at the discriminator output to attempt to determine the presence of a valid synchronization pattern. This can lead to falsing on noise and signals which may happen to have the same signature as the synchronization pattern. Although the error detection and CRC algorithms within the modem are powerful enough to prevent false data from ever being passed to the host, the modem may miss a valid packet while trying to decode noise. On the other hand, using the carrier detect circuit to inhibit signals from passing into the modem until and unless a carrier of sufficient has been detected makes the modem's detection of a valid synchronization pattern slightly more reliable. However, the carrier detect circuit looks at the RF level of the incoming signal and can open on noise if the noise level is high enough. This is common on the VHF band. In order to prevent false carrier detect operation, the carrier detect threshold must be set to the equivalent of a 20 dB SINAD signal or better.

In general, for best data modem sensitivity, the carrier detect circuit should not be used, but for best overall throughput i.e. lowest ultimate BER, the carrier detect circuit should be used. RF Neulink recommends that for most setups, that carrier detect not be used.

6.0 Configuration Software

To configure the NL6000 Module, the RF NEULINK PC Configuration Software Kit, NL5000P-PCKT, must be used.

6.1 PC CONFIGURATION SOFTWARE KIT

The user should install the Configuration Software on the host computer. The RF NEULINK adapter cable connects the modem to a computer's serial communications port. Once the cable is hooked up, the user runs the Configuration Software software. This program transfers data between radio and computer memory.

6.1.1 Configuration Software Kit Contents and Requirements

The Configuration Software Kit for NL5000 (via compatible computer) is model NL5000P-PCKT. It includes:

1. Configuration Software disk, CD (qty 1).
2. Configuration Software/Power cable-a cable with a DB-15M connector on one end for connection to the NL5000 modem and a cable to a DB-9F connector for connection to the host computer and two wires, one red (positive) and one black (negative) for connections to a power supply.

Note: Ensure that the correct power supply voltage is available for the modem model used and that said power supply can supply the required current. A regulated supply is strongly recommended. Unregulated wall-mount supplies are NOT recommended. Switch mode supplies work well if they are kept at least two feet from the antenna.

The Configuration Software Kit requires a PC compatible computer with Windows 95 or later operating system installed. The computer must have an RS-232 serial port available. A hard disk and CD drive is also required.

6.2 LOADING THE CONFIGURATION SOFTWARE SOFTWARE

Insert disk one of the two disk set in the floppy disk drive. View the contents of the floppy disk and double click on the install.exe file. Follow the instructions as they appear on the screen including the prompt to insert the second disk. At the conclusion of the installation procedure, the Configuration Software will be resident on the user's host computer.

6.3 COMPUTER SOFTWARE COPYRIGHTS

The RF NEULINK, Inc. products described in this manual include copyrighted RF NEULINK, Inc. computer programs. Laws in the United States and other countries grant to RF NEULINK, Inc. certain exclusive rights in its copyrighted computer programs, including the exclusive right to distribute copies of the programs, make reproductions of the programs, and prepare derivative works based on the programs. Accordingly, any computer programs contained in RF NEULINK, Inc. products may not be copied or reproduced in any manner without the express written permission of RF NEULINK, Inc. The purchase of RF NEULINK, Inc. products does not grant any license or rights under the copyrights or other intellectual property of RF NEULINK, Inc. except for the non-exclusive, royalty fee license to use that arises in the sale of a product, or as addressed in a written agreement between RF NEULINK, Inc. and the purchaser of RF NEULINK, Inc. products.

6.4 USING THE CONFIGURATION SOFTWARE SOFTWARE

Upon starting the Configuration Software a progress bar will be displayed showing the progress of loading the Configuration Software. Once the Configuration Software has been loaded a screen with the frequencies of the two programmable channels will be visible along with three drop-down menus at the top and three buttons at the bottom. The functions of these menus and buttons will be explained in detail below.

A few notes about using the Configuration Software:

- Moving from menu item to menu item and from screen to screen may take from 1 to 7 or 8 seconds. Some commands require that the entire contents of the radio's memory be accessed. An hourglass symbol may or may not be present for some or all of that time.
- If the Configuration Software acts as if it is accepting commands, but the radio does not appear to be responding, exit the Configuration Software and start over. A power glitch on the radio during the middle of a Configuration Software session can cause a serial communications conflict.
- The adjustments on the alignment menu are somewhat slower than changes in settings on the settings menu. More computations and radio memory communications are required on the alignment items.

6.5 CONFIGURATION SOFTWARE BUTTONS

The Configuration Software has three buttons at the top of the Welcome screen. These functions are as follows:

1. *Program Radio*-This button begins the Configuration Software process.
2. *Configuration Software Configuration Software*-This button is used to select the correct host computer communications port and the correct serial baud rate. The default is port 1 and 9600 bps.
3. *Exit*- Selecting this button will close the Configuration Software. The exit screen will allow the user to continue to exit, cancel the exit command, or allow the current radio Configuration Software to be saved.

The Configuration Software has three buttons at the bottom of the frequency screen. These functions are as follows:

1. *Receiving*-This button allows the unit to be keyed via the Configuration Software and overrides the test pin on the I/O connector. When selected, the button will display *transmitting*.
2. *Monitor*-This button overrides the internal squelch system and opens the receive audio gates so that audio is present on the two audio outputs regardless of RF signal level. When selected, the button will display *open squelch*.

3. *Exit*-Selecting this button will close the Configuration Software. The exit screen will allow the user to continue to exit, cancel the exit command, or allow the current radio Configuration Software to be saved.

6.6 CONFIGURATION SOFTWARE DROP-DOWN MENUS

The NL5000 Configuration Software has three drop-down menus, selectable via tabs at the top of each page, which are always visible. These menus are:

6.6.1 File

Allows the management of Configuration Software files. There are four sub-menus under this menu:

Open File-Opens a previously saved Configuration Software file. This is used to copy one radio modem's Configuration Software to another. This is of benefit when a number of radios are to be set to the same frequencies and with the same switch settings.

Save File-Allows the current Configuration Software to be saved. This feature is also presented upon exiting the Configuration Software.

Print-Prints a summary of the current Configuration.

Change Password-Allows the password for the Configuration Software to be changed. Note that the password is specific to the Configuration software and not to the radio modem. A password is required to access the alignment page or to update firmware.

Quit-Exits the program. Upon exiting the Configuration Software via the exit button, the user will be presented with a box which allows the saving of the current Configuration. This is useful if a number of other radios are to be programmed with the same frequencies and settings. If one does not wish to save the current Configuration, the exit button should be selected.

6.6.2 Radio

Read-Reads the radio's Configuration. This would normally take place when the Configuration Software is opened, but if a radio is disconnected and another radio is connected, this sub-menu function would force the program to update itself with the new connected radio.

Summary-Presents a summary of the radio's entire configuration on one screen.

Upgrade Firmware-Brings up a screen which allows upgraded firmware to be loaded into the radio.

6.6.3 Edit

Frequency-Brings up the page where channel frequencies can be entered. This is the page which first appears when the Configuration Software software is opened.

Settings-Allows the basic settings of the radio modem to be set. This would include enabling functions such as squelch, transmit timeout timer, etc.

Alignment-Allows setting of the radio's alignment items such as output power, deviation, squelch open and closing points, etc.

Modem-Allows selection of the modem parameters.

Terminal Mode-Opens a terminal window which should only be used by experienced technicians.

The above sub-menus are explained more fully below.

6.6.3.1 Frequency

The Frequency page has fields for the transmit and receive frequencies for each of the two channels which can be selected via the 15-pin connector A/B line as well the ability to show the entire 8 channels which can be stored in the modem.. Channel information can be entered by clicking on the appropriate box and entering the desired frequency.

If the Channel Expansion box is checked at the bottom of the frequency page, eight channels will be shown. Checking the box to the left of each channel selects that channel, even after the Configuration software is closed and even if the radio modem is removed from power. When the modem is forced to a channel by checking a channel box, the A/B line on the 15-pin connector may be used for high/low power only. Via a box on the settings page, the power control may be set up so that it operates in a high/low mode selected by the A/B line or always in high power.

The command sequence for forcing the modem to a specific channel is detailed in the appendix.

The frequency chosen must be within the operating range of the radio and on a frequency for which the synthesizer is capable of channeling i.e. for VHF, divisible by 2.5 kHz, for 220 MHz, divisible by 2.5 kHz or 3.125 kHz, and for UHF, divisible by 5 or 6.25 kHz. If the entered frequency is out of band, it will not be accepted. If the entered frequency is not on an appropriate synthesizer step, it will be rounded to the nearest step.

6.6.3.2 Settings

The Settings page allows for Configuration of various parameters of the radio. These are detailed below:

TX Pre-emphasis-Allows for the signal path from AUX IN to be either pre-emphasized or flat. Most applications where external data is being transmitted work best with a flat response. Voice signals from a microphone work best with pre-emphasis selected. Changing this setting changes the gain of the audio input which may require setting a different audio input gain on the alignment page. Factory default is flat response.

Busy Channel Lockout-Prevents the transmitter from activating when the carrier detect output is true. Used to prevent interference on a channel where activity already exists. Not normally enabled in half duplex operation since the transmit and receive channels are not on the same frequency. Factory default is for this function to be off.

Test Pin (PTT) Input Logic Level-Sets the polarity of the PTT input via the TEST pin on the 15-pin I/O connector. Normally set for active low i.e. transmitter is activated when this input is at the logic low state. **Due to the internal pull-up resistor, setting this to active high will cause activation of the transmitter when the PTT input is left unconnected.** The factory default is active low.

TX Timeout Timer-Allows for limits on the maximum time the transmitter may be continuously keyed. When set, the maximum limit is set in the box. To prevent overheating and possible damage to the unit, this is normally set on with a time of 60 seconds or less. See section 5.3 for limits on maximum key-down times. The factory default is 60 seconds.

A/B Input One or Two Channel-Sets how the A/B input on the 15-pin connector is to be used. This pin may be either used to select between the two channels or to switch between preprogrammed low and high power settings. When set for High/Low power, the channel defaults to channel A.

A/B Input Expanded Channels-Active when expanded channel is selected on the frequency page. The A/B input can be set to control high/low power or set so that the unit is always in high power regardless of the A/B input state.

Uart Rate-Allows for setting of the data rate of the serial connection between the host computer and the modem. The default rate is 19200 bps.

RX De-emphasis-Allows for the signal path from the discriminator to the AUDIO OUT to be either de-emphasized or flat. Most applications where external data is being sent work best with a flat response. Voice signals, however, usually work best with de-emphasis selected. Factory default is for flat response.

RX Discriminator Coupling-Selects whether the coupling from the discriminator output on the RF board is AC or DC coupled to the control/loader board. Since the audio outputs of the modem board are AC coupled, this function is normally set for AC as well. For response to DC, modifications must be made to the modem board. The factory default is AC.

CD Output Logic Level-Allows the setting of the polarity of the Carrier Detect output. Active high means that the true state is a logic high while active low means that the true state is logic low. Normal setting is active high. The factory default is active high.

Squelch Enable-Allows the receive audio paths to be muted when the carrier detect output is false. Used to prevent the output of noise from the audio outputs when no signal is present. The factory default is for this function to be set for squelch on.

Flow Control-Sets the method of controlling the flow of data between the host device and the radio modem. Three selections are available, none, hardware, and Xon/Xoff. If 'none' is selected, no flow control is provided i.e. the modem and host must accept data anytime the other has data to send. Hardware flow control refers to the use of the RTS/CTS lines to control the data from the host to the modem. (There is no flow control in the opposite direction.) Xon/Xoff refers to flow control using special characters in the data stream itself to control data flow.

6.6.3.3 Alignment

The alignment menu is password protected and is used during the alignment process. Details on its use may be found in the Maintenance Section (Section II) of the complete manual.

6.6.3.4 Modem

The modem menu allows the modem source and destination addresses to be set up as well as allowing the setting of various protocol parameters.

Source Station ID-Sets the address of the modem itself. It is made up of 4 parts, from most general to most specific: System ID, Group ID, Unit ID, and Sub-unit ID.

Default Destination ID-Sets the destination ID of the intended recipient.

Modem Protocol-Indicates the protocol version number and a button which opens a menu allowing various parameters of the protocol to be set. These parameters are detailed in the next section.

6.6.3.5 Protocol

Configuration Software

Acknowledgement required after transmit-When checked, the modem requires an acknowledgement after each transmission or the transmission will be repeated. The amount of time that the modem will wait for an acknowledgement and the number of times it will repeat a message can be set in the Message Retry Limits box and the Time Out Time box on the Configuration Software page.

Sync Method

Selects which message detection method will be used by the modem for reception. In the R4S method, the modem looks at raw discriminator audio for the sync pattern of the transmitted message. In the Carrier Detect method, the modem looks for the sync pattern, but only after a valid carrier is detected. See Section 5.7 for details and tradeoffs between these two methods.

Protocol Mask

The protocol mask determines how close a mask must exist between the modems ID and the destination ID in the message before accepting and outputting to the host the message. A '1' for any location in the mask requires a perfect match, while a '0' means a 'don't care' situation. This is useful for 'broadcast' i.e. one unit transmitting to more than one unit situation. Note: In broadcast applications, the 'Acknowledgement after TX' selection should NOT be selected to prevent multiple units from responding and interfering with each other.

Dead Carrier before Symbol Sync-Value in 300 ms increments to set the amount of time a dead carrier should be sent before starting the transmission of a message. This allows a transmitter to get set on frequency before the beginning of a message. For the NL5000, this value can be set to zero.

Delay before Symbol Sync-Value in 300 ms increments to set the amount of delay after the detection of a carrier before starting to look for the beginning of a message. This parameter is the receiver corollary to the 'Dead Carrier before Symbol Sync' parameter in that it allows for the transmitter to get on frequency before beginning to look for a message. This parameter is only used with the carrier detect method of detecting a message and for the NL5000 can be set to zero.

Message Retry Limit-Number of times the unit will retransmit a message in acknowledgement mode when an acknowledgement is not received.

Time Out Time-The length of time in 26 ms increments that the unit will wait for an acknowledgement when in acknowledgment mode.

Partial Packet Time Out-The length of time in 26 ms increments that the unit will wait for data from the host before sending a packet in those cases where the transmit buffer is not full.

6.6.3.6 Terminal Mode

The terminal mode allows for direct control of the radio modem and its memory map via a set of special proprietary commands. This mode is used by RF Neulink for troubleshooting and for implementing special functions.

APPENDIX

A CONFIGURATION MODE W/O THE CONFIGURATION SOFTWARE

The NL5000 modem can be placed in Configuration mode without the Configuration Software being connected if the user sends the same sequence of characters to the modem that the Configuration Software does when it wishes to place the unit in Configuration mode. After power-up, the modem should be sent a sequence of three ASCII '+' characters, each separated by 1 second in time. Note that in Configuration mode, the modem will echo each character it receives while in normal modem mode, it will not. The unit will stay in Configuration mode until power is removed or until an ASCII *00<cr> is sent to reset the unit and take it out of Configuration mode. Note: <cr> is the ASCII carriage return character.

B COMMANDING A CHANNEL CHANGE W/O THE CONFIGURATION SOFTWARE

To force the modem to a particular programmed channel, the channel number must be sent to the modem while it is in Configuration mode. This requires first that the unit be placed in Configuration mode. See Appendix A for instructions for doing this.

Before commanding that the modem go to a specific channel, it is sometimes helpful to determine the default channel number for multi-channel modes. This requires sending a command to read the particular address in the modem's memory which contains the current channel number. This is done by sending the following ASCII sequence:

```
*02026201019640<cr>
```

<cr> is an ASCII carriage return.

The modem will respond with:

```
dd<cr><lf>
```

where dd is the channel number in ASCII coded hex and <lf> is an ASCII line feed.

Example:

One wishes to read the default channel number when in multi-channel mode. The command would be:

```
*02026201019640<cr>
```

The modem might reply with:

```
07<cr><lf>
```

which would be channel 8. Note that the channel number is one greater than that stored in memory since the unit stores channels from 0 to 7 while channels are represented to the user from 1 to 8.

The memory write command is similar the read command except that additional characters are placed on the end. The command sequence for writing the default channel number is:

```
*02026201019640004452000000000000000080<cr>
```

Note that there are 16 '0s' between the 52 and the 80 characters.

One could then issue a channel read command as illustrated above to verify the write operation.

If one wishes to program to channels above 2 (actually 01 in the modem's memory), the expanded channel bit in the channel expansion memory byte must be set as well. This is done by the following command:

```
*020262030000004452CF0000000000000080<cr>
```

Note that 14 '0s' are sent between the CF and 80 characters.

Finally, *00<cr> should be sent to perform a software reset which makes the change effective and takes the modem out of Configuration mode.